

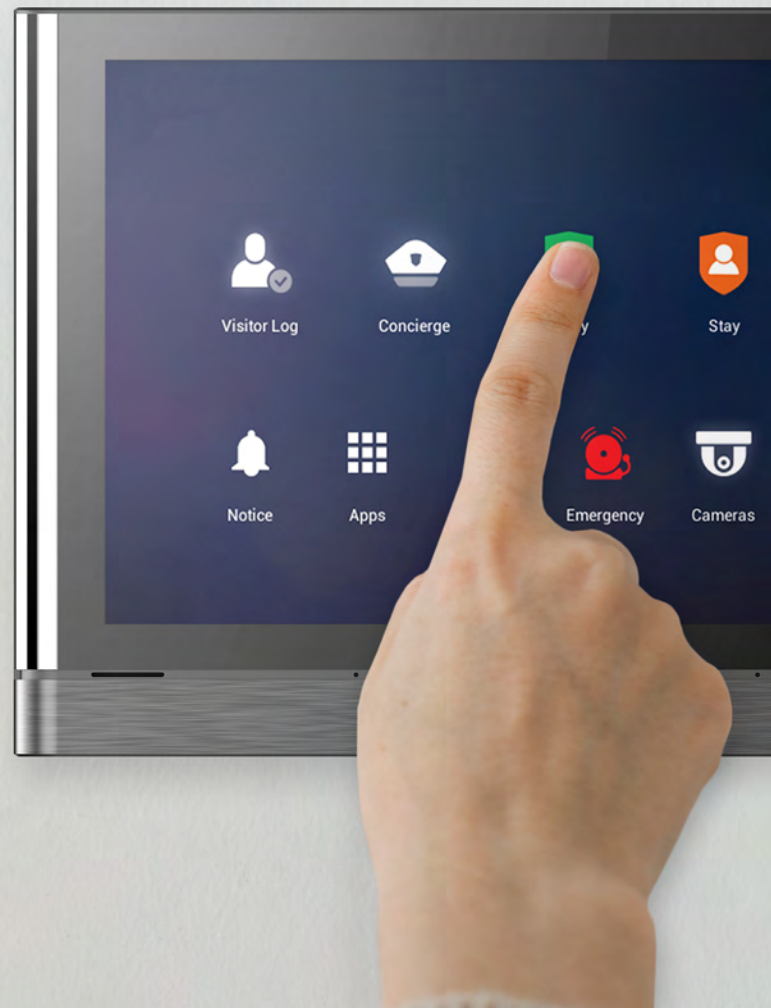

User Manual

The skyline is getting smarter

Scan the following QR Code for the digital PDF version of this User Manual, plus additional onboarding tools:

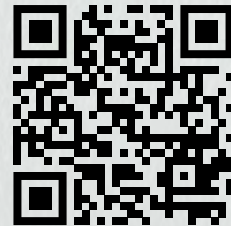

Contents

Some of the features listed below may not be available in your community at this time

1.0 Overview

1.1 Wall pad

- ① LCD Touch Screen
- ② Speaker
- ③ Power Switch

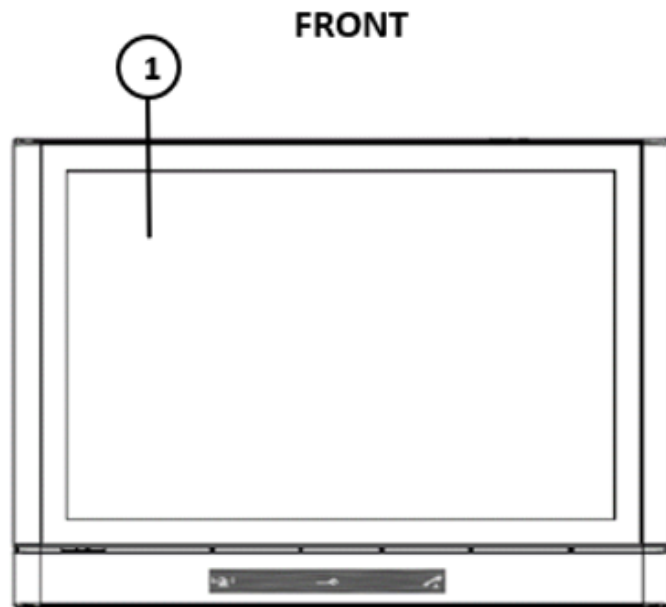

BOTTOM

1.2 Wall pad home screen

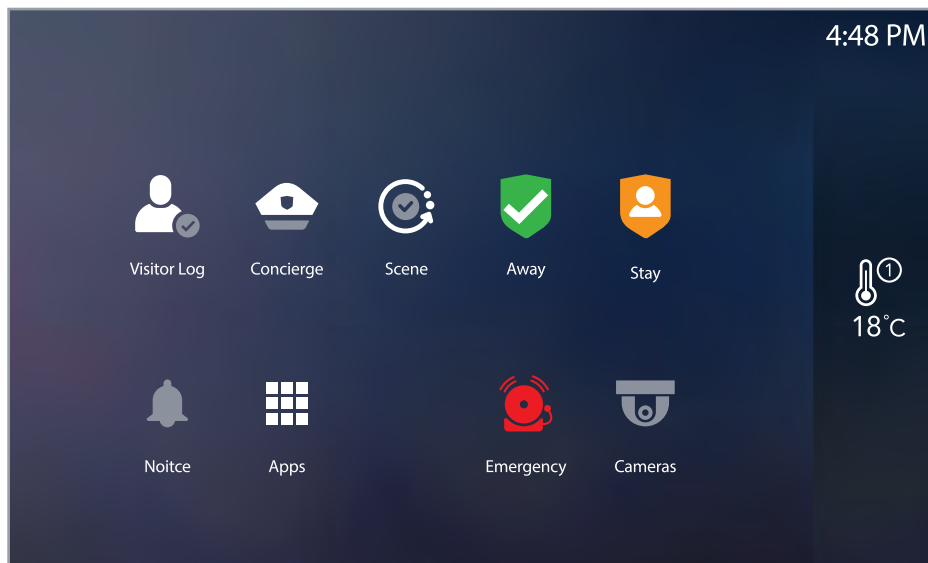

Wall Pad Home Screen.



VISITOR LOG

View and manage the captured images of visitors



CONCIERGE

Call the Concierge



AWAY

Set the 'Away Mode' security setting



STAY

Set the 'Stay Mode' security setting



NOTICE

View and manage posted notices



APPS

Installed apps



EMERGENCY

Activate suite alarm



CAMERAS

View Security Cameras within your community



THERMOSTAT

Set and program thermostat(s)



SCENE

Program or activate desired "Scene"

The SmartONE solution is a video phone system, which allows video phone calling from select entrances throughout the community. When a visitor calls your suite from the main lobby or one of the select entrances, the wall pad will display the visitor and the control options shown below.

- ① Call Status
- ② Display of person calling
- ③ Volume setting
- ④ Answer call
- ⑤ Refuse call or hang up
- ⑥ Open door
- ⑦ Capture the image of the visitor

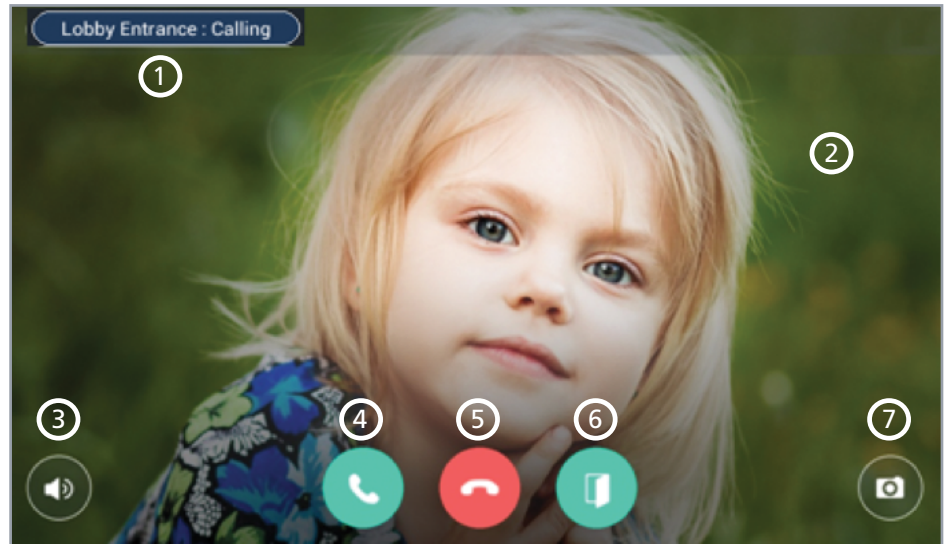

Image of person calling from entrance.

When a visitor calls your home from one of the select lobby entrances, the wall pad will change to the video call screen shown above:

- The caption on the top left displays the location of the call ①
- The main screen shows the image of the person at the lobby entrance ②
- The volume of the call can be adjusted by pressing the speaker symbol ③
- To answer the call, press the green phone symbol ④
- To end the call, press the red phone symbol ⑤
- To open the door, press the green door symbol ⑥
- To capture a picture of the visitor, press the camera symbol on the bottom right ⑦

Captured pictures can be viewed on the visitor log screen, which is accessed from the home screen. The system will store up to 128 images per wall pad and when image capacity is full, the oldest image will automatically delete.

📷 Visitor cameras on the lobby phone can also be viewed on your ONE! app. You can unlock the front door, but will be required to enter your suite security PIN to grant access from your mobile device for security purposes.

🔒 When your suite is in the 'Away Mode' security setting, a visitor picture is automatically captured if the 'capture visitor picture' setting is ON in the alarm settings screen. Details on how to review alarm settings is shown in section 8.5 of this manual. The automatically captured pictures of visitors will show up as a 'missed call' within Visitor Log screen.



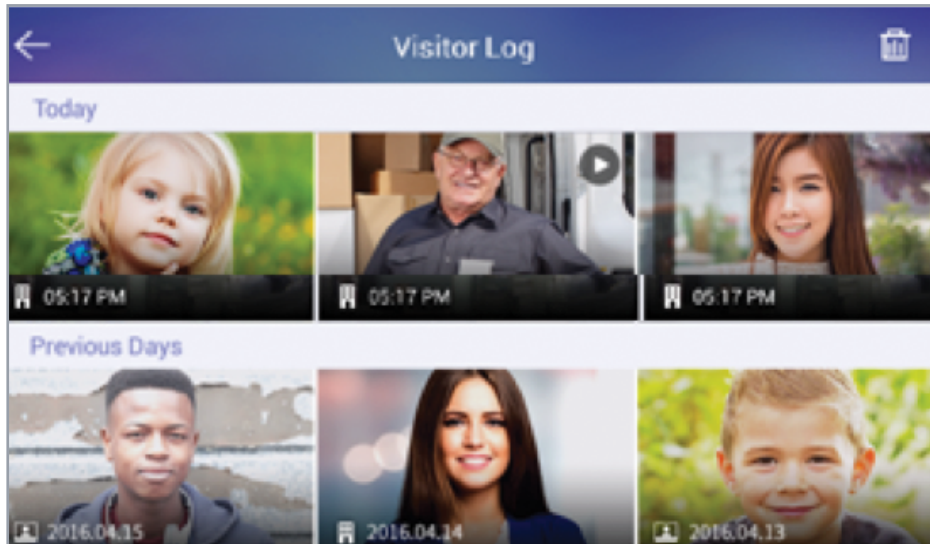

Pressing the Visitor Log icon on the home screen will allow you to view and manage the recorded images of visitors.



View and manage the saved images of visitors.

3.1 Viewing recorded images

There will be a timestamp shown for images that are saved on the current day, and the date and timestamp will be shown for images that were saved on previous days. To view older images, scroll down on the image viewing screen to older pictures. Touching the screen to select an image will enlarge it to the full size of the screen and the left and right arrow buttons can be used to scroll through the stored images. Delete unwanted images using the trash can icon .

 Stored Visitor Log images can also be viewed from the ONE! app. Images can only be deleted from the wall pad in the suite.

3.2 Deleting recorded images from the main visitor log screen

- 1) Touch the trash can icon 
- 2) Select individual images or all images by selecting the 'Select all' box
- 3) Images may be unselected by tapping them again
- 4) Touch the 'Delete' button to delete the selected images

 The system will hold a maximum of 128 images per suite. The oldest images will be automatically deleted once the maximum number is reached.



4.1 Calling the concierge



If your community has a designated concierge desk, touch the 'Concierge' icon on the main screen, or press the 'Concierge' icon at bottom of the wall pad to call them.

4.2 Receiving a call from the concierge

When a call is received from the concierge, the wall pad rings and displays a message 'Concierge Calling' on the top left of the screen.

- To answer the call, touch the  (Call) button
- To reject a call, touch the 'Cancel' button
- To hang up a call, touch the 'End call' button 

 The Concierge cannot see you during a Concierge call but you are able to see the Concierge.

When a call is received from the concierge, not only will it be displayed on your wall pad, but also through your ONE! app. To answer/reject such calls please use your smartphone's native method of accepting/declining calls.

4.3 Call switching function

If someone from the lobby calls you during a concierge call, you will receive a message on the top left of the screen that the Lobby is calling.

Touch the  (Switch call) button to answer the call. The previous call will be disconnected once you transfer to the new call.



EMERGENCY ALARM

Activates an emergency alarm in the suite.



AWAY MODE

Activates the 'Away Mode' security setting.



STAY MODE

Activates the 'Stay Mode' security setting.

5.1 Suite emergency alarm



You can activate the suite emergency alarm by pressing the Emergency Alarm icon. When this alarm is activated, the suite will go into alarm mode and all paired smart phones will be notified of the emergency along with the concierge.

Please note that 911 should be called during any life-threatening emergencies.

When the suite Emergency Alarm icon is pressed, the confirmation screen shown below will be displayed, allowing you to proceed with the alarm by pressing the 'Yes' button or to Cancel by selecting the  back button.

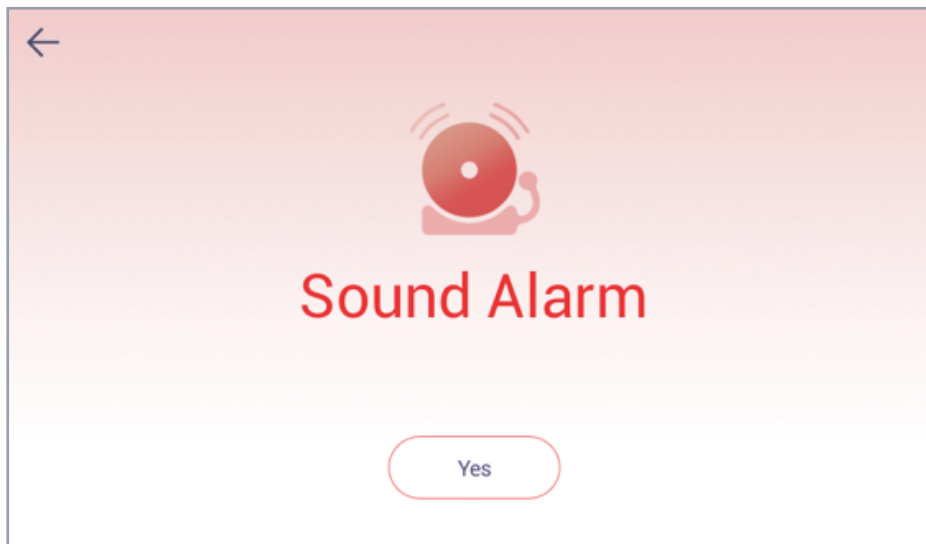

Confirmation Screen to Sound the Suite Alarm

5.2 'Away Mode' security setting



The 'Away Mode' icon is selected when you leave your suite and would like the security alarm activated. When the suite is in 'Away Mode', the home screen appears as shown below. Please note the green indicator circle at the bottom of the screen shows that the suite is in "Away Mode".

You can set 'Away Mode' from your ONE! app by pressing the 'Away Mode' icon.

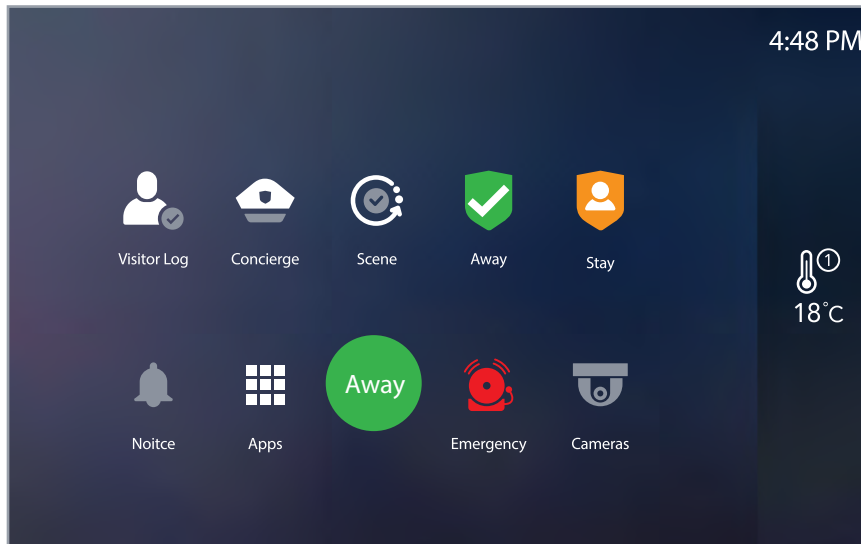

Security Set to Away Mode

What happens when you are in 'Away Mode'?

When 'Away Mode' is set, the thermostat(s) in the suite will automatically be set to the 'Away Mode' temperature for that thermostat. (For instructions on setting the 'Away Mode' settings on the thermostat, please see section 8.6). 'Away Mode' will also trigger the automatic photo capture of visitors at the selected entrance areas. You can adjust the alarm settings to set the amount of time for the alarm to activate when you leave the suite and the amount of time allowed to deactivate the alarm when you return in the alarm settings screen shown in section 8.5 of this manual.

Returning home after 'Away Mode' has been set

When you return home and the suite is in 'Away Mode', the wall pad will play an audible jingle to alert you that the suite security alarm is set. When you touch the wall pad, you can select 'Dismiss' to deactivate the Alarm. When the 'Dismiss' button is pressed, the alarm password screen appears. Input your four-digit password to dismiss the alarm. (The default password is '1234' and it will change after the initial setup of the wall pad.)

Please see section 8.7 of the manual for how to change your security password.

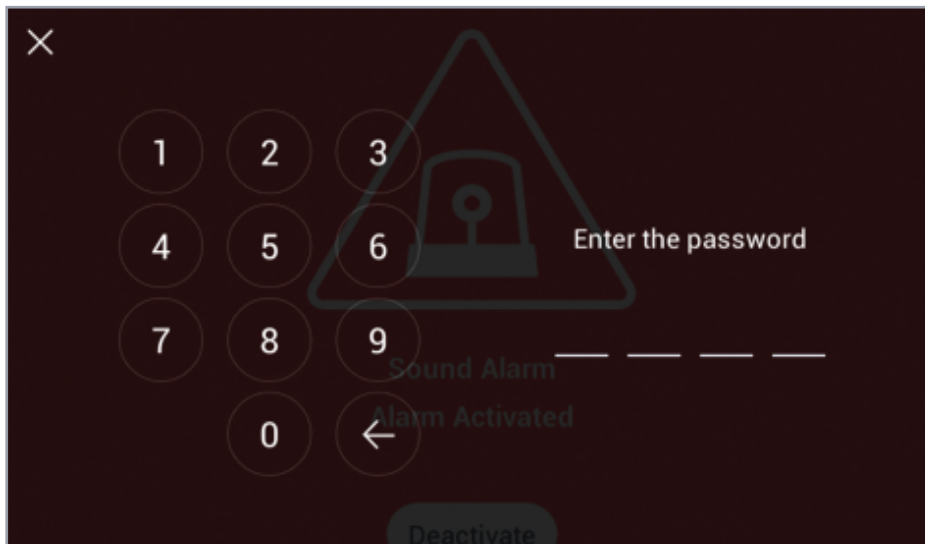

Password Entry Screen to Dismiss the Alarm

⚙️ If a valid password is not input within (20) twenty seconds or three incorrect entries are made, the suite alarm will sound.

5.3 'Stay Mode' Security Setting



The 'Stay Mode' security setting is selected when you are home and would like the security system activated. When the suite is in 'Stay Mode', the home screen appears as shown below. Please note the orange indicator circle at the bottom showing that the suite is in 'Stay Mode'.

You can set 'Stay Mode' from your ONE! app by pressing the 'Stay Mode' icon.

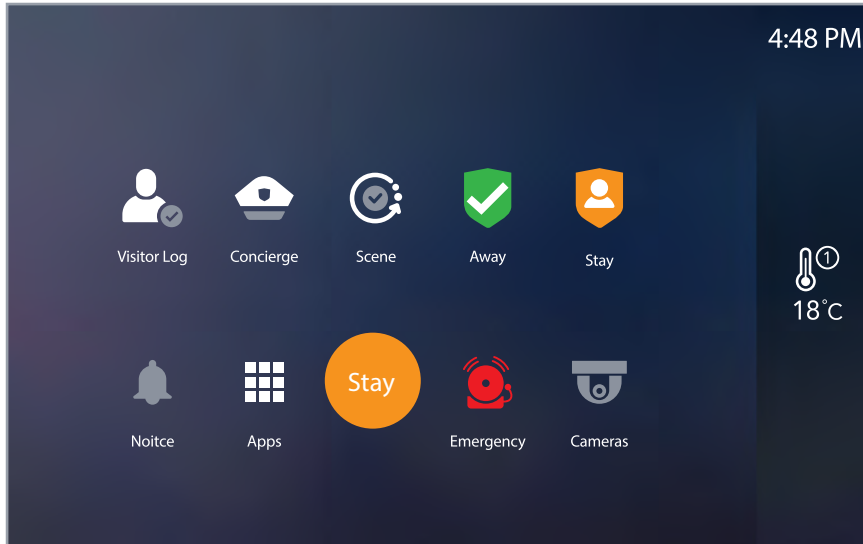

Security Set to Stay Mode

What happens when you are in 'Stay Mode'?

When 'Stay Mode' is set, the thermostat(s) in the suite will remain at the current set temperatures. If your suite has motion sensors integrated into the alarm system, they will be bypassed, allowing for movement in the suite without activating an alarm.

What happens if the suite entry door is opened in 'Stay Mode'?

Opening the suite entry door while the suite is in 'Stay Mode' will immediately sound the suite alarm, notifying all paired smart phones and the concierge.

5.4 Setting and viewing alarm settings on the ONE! app

The alarm may be set to 'Away' or 'Stay' mode by selecting the appropriate icon on the home screen of the ONE! app. The alarm condition of the suite is indicated by the small circle at the top of the app screen. The picture below is the ONE! app showing a suite that is in 'Away' mode.

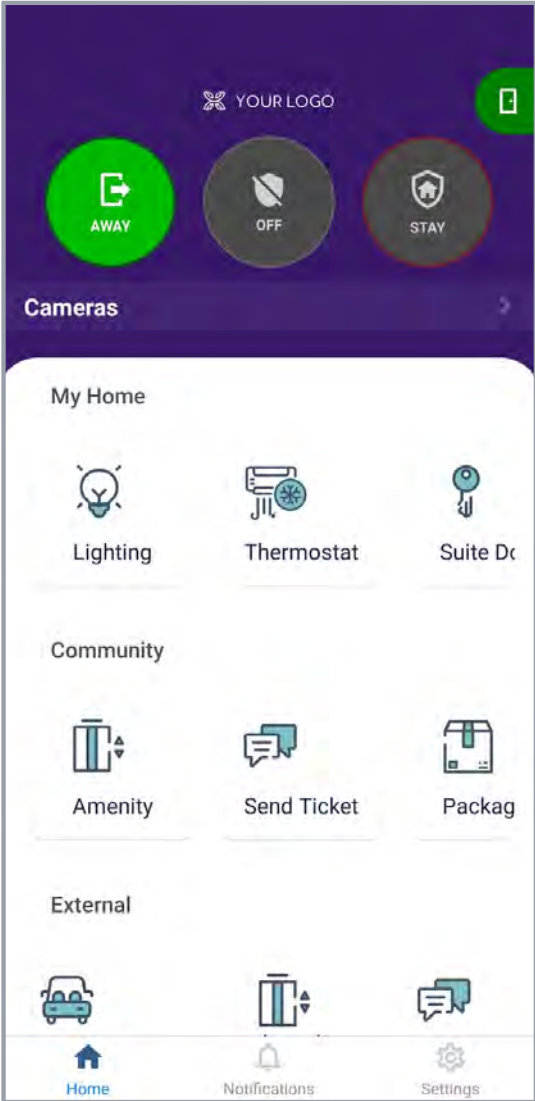

ONE! App Screen in 'Away' Mode

5.5 Dismissing the alarm

When the suite is in Alarm Mode, the smartphones that are paired to the suite will be notified, as well as the concierge station.

To stop the alarm, press the 'Deactivate' button located at the bottom of the emergency screen.

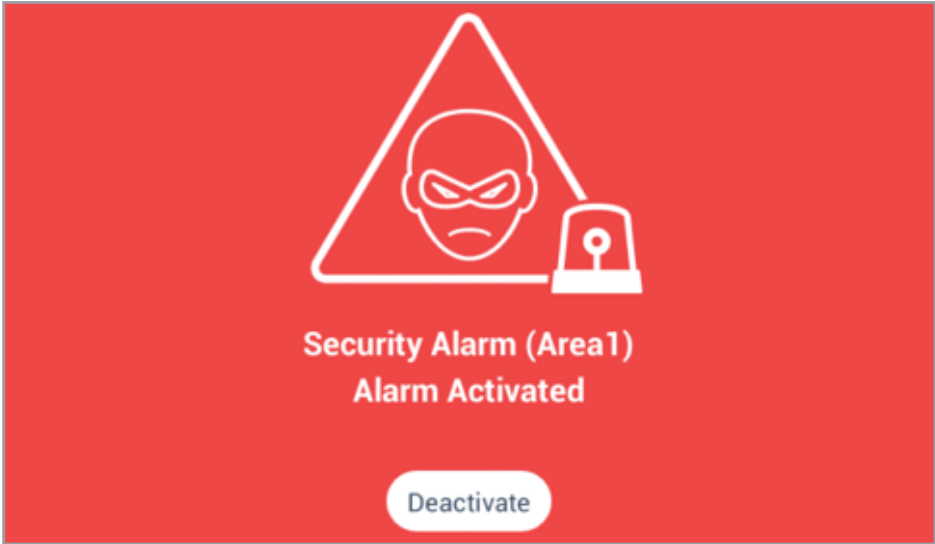

Suite Emergency Screen

Input your four-digit password to dismiss the alarm.

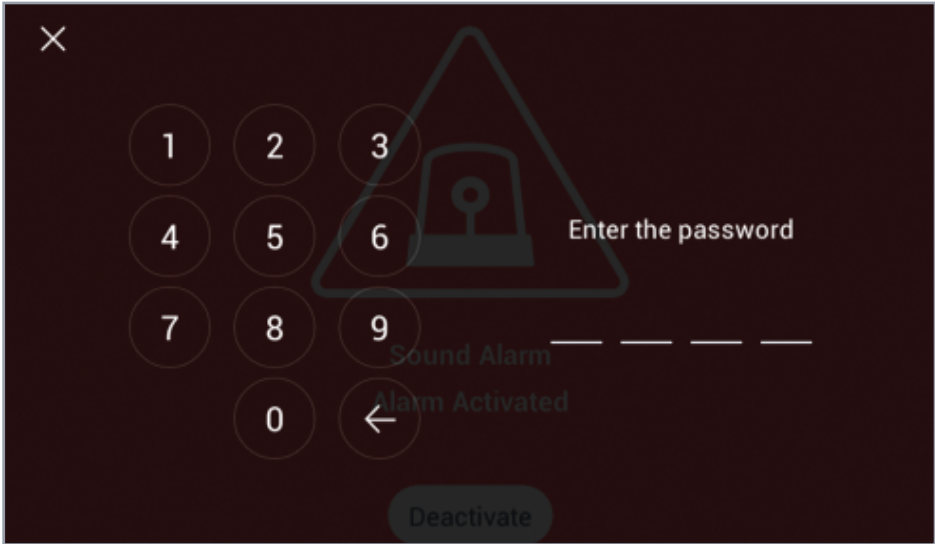

Password Input to Deactivate the Suite Emergency Alarm

To change the four-digit code (password), start at the home screen and select the  Apps Icon and follow 'Apps -> Settings -> User Configuration -> Password'. Please see section 8.7 of the manual for additional information.



The Property Management Team will be sending community notices to your in-suite wall pad. The notice icon on the home screen has a counter to display the number of new messages you have received. Pressing the notice icon will launch the notice screen shown below. Selecting an individual notice will open the notice and mark it as read. A notice may be deleted by selecting the message and pressing the trash can symbol .

Notices can also be viewed and deleted from the ONE! app.

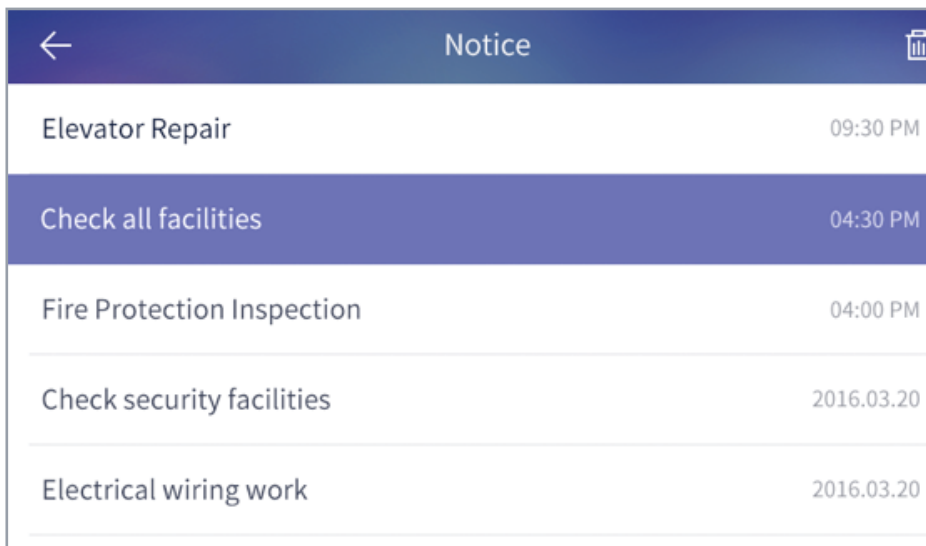

Notice	
Elevator Repair	09:30 PM
Check all facilities	04:30 PM
Fire Protection Inspection	04:00 PM
Check security facilities	2016.03.20
Electrical wiring work	2016.03.20

Notice Screen



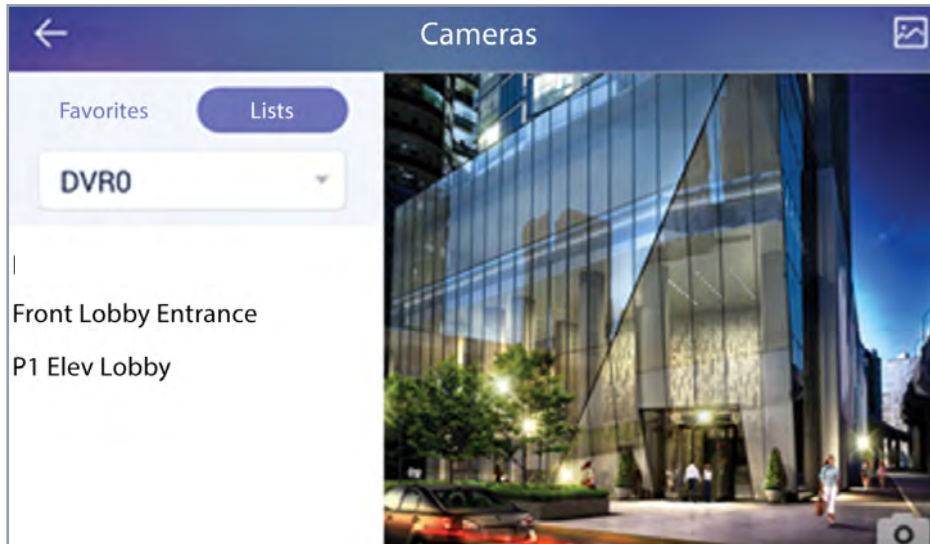

The camera screen allows you to view designated cameras throughout the community.



View and manage the saved images of visitors.

The left bar of the screen shows the cameras that are available for viewing. A camera may be selected by pressing its name on the list. When a camera is selected, the image from that camera is displayed on the main screen. If suspicious activity is viewed on a camera, a picture can be captured by pressing the  icon at the bottom right of the screen.

To view captured pictures, select the  icon on the top right corner of the screen. Selecting the  icon will display the screen shown on the next page.

7.1 Reviewing photos

You can select a picture to display as full size then use the left and right arrows to scroll through pictures. A selected image can be deleted by pressing the trash can  icon.

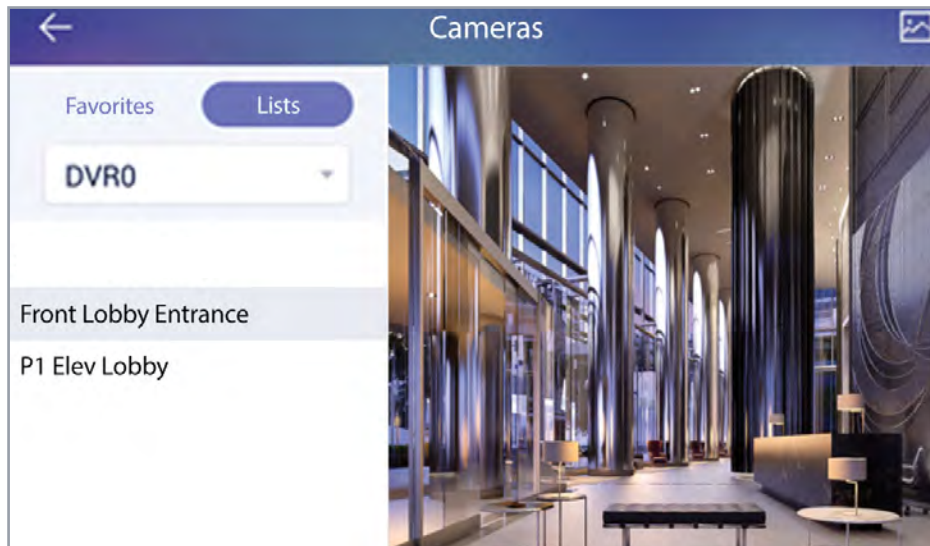

Review and Manage Captured Images

 Cameras may also be viewed from the ONE! app, but please note that the image capture function is not available from mobile devices. Pictures may only be captured from the wall pad.

 The images captured in the camera views will be included in the total number of pictures that can be saved, within your wall pad, up to a total of 128 images total.



The Apps screen contains the settings menu and various applications. You can navigate the screens in the apps area using the home and back buttons shown below.

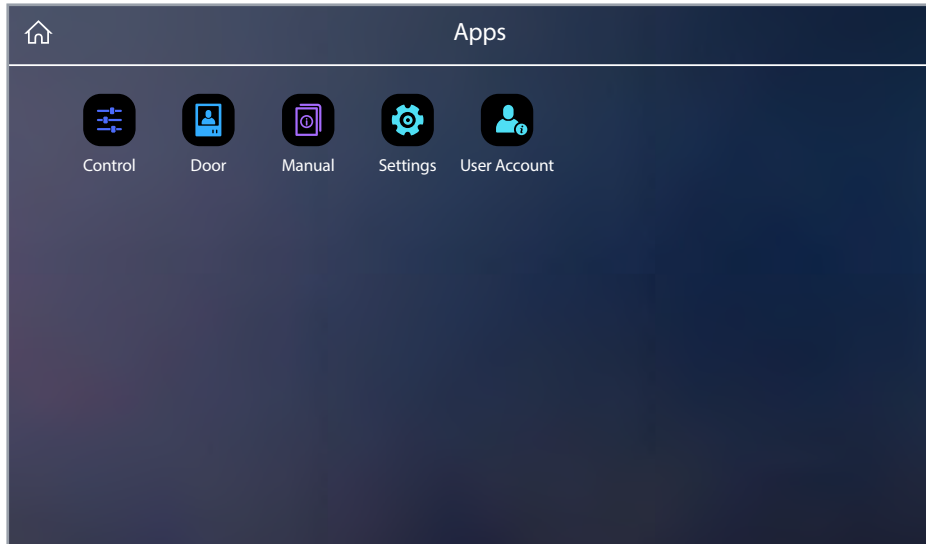

Apps Screen

8.1 Manuals

Selecting the Manuals icon will display the screen below.

Manuals may also be viewed in the ONE! app.

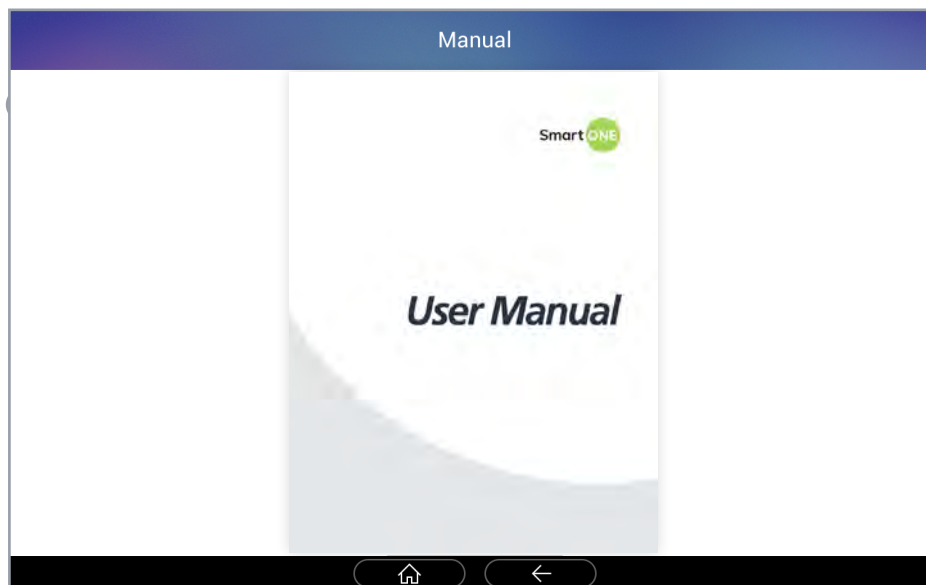

Manuals Screen



GO TO HOME SCREEN



MOVE BACK TO PREVIOUS SCREEN

8.2 Sign Up – registering your smartphone to your suite and door lock

Step 1: Get the ONE! app

Let's start by downloading the ONE! app. This app can be found in both the Apple and the Google Play store by searching '**SmartONE Solutions**'. The app will work with the majority of Android and IOS platforms.



Step 2: Open the ONE! app

1. Create a user account by filling in the required information
2. You'll receive an email from 'SmartONE Solutions' with a 6-digit security code
3. Enter in the security code field
4. Follow the prompts to set up your password
5. Review and accept the Privacy Policy and Terms and Conditions
6. Once directed to the login screen, please login using the email address and password you just created

Step 3: Authenticate your account with your suite using your wall pad home screen

1. Click **Apps > User Account**. You'll now see a QR code on the left side of your wall pad screen



2. With the ONE! app opened on your smartphone, click the green **ONE** icon to connect
3. This will activate the camera on your smartphone to scan the QR code on your wall pad
4. Scan the QR code on your wall pad screen with your smartphone camera
5. For your security, you'll be prompted to enter a six-digit code generated by your wall pad to successfully pair to your suite
6. Follow the step-by-step instructions shown on the ONE! app to retrieve your six-digit code from your wall pad. These steps are also found starting on the next page of this document.

8.3 Settings

Pressing the settings button and then selecting 'User Configuration' under the 'Commax' menu will display the screen below (Settings -> User Configuration -> Commax).

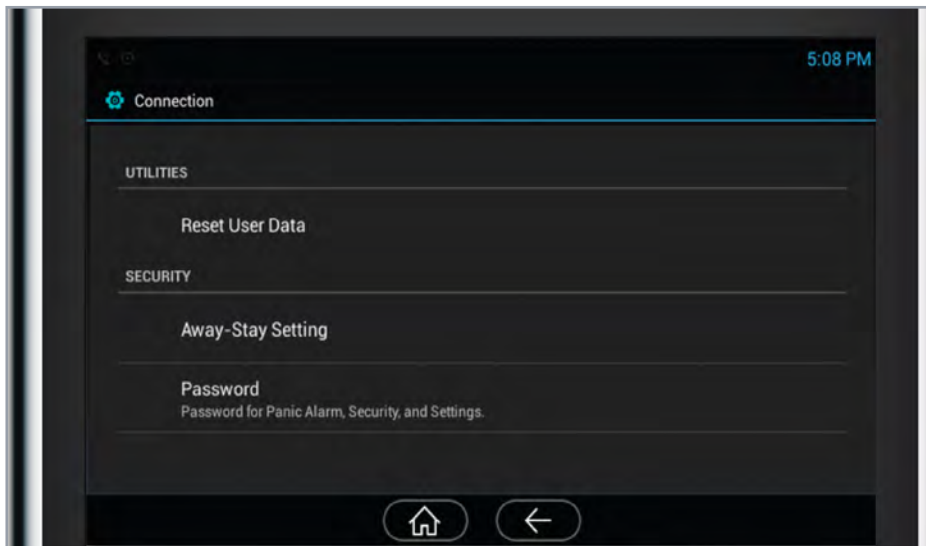

Settings User Configuration

8.4 Reset User Data

This function was created to clear the system when people move out of a suite and new people move in. This function will clear any saved pictures that have been stored on the wall pad, it will reset the security password for the wall pad to '1234' and disconnect all paired smartphones.

8.5 Change Language Settings

To change the language settings in your wall pad, click on **Apps** and then click on **Settings**.

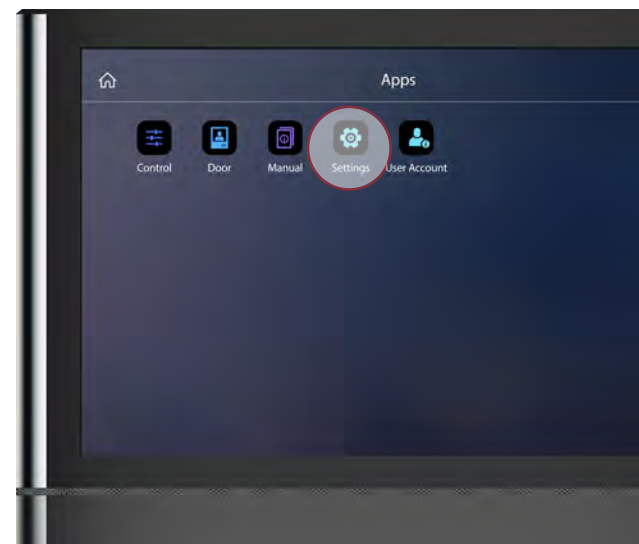
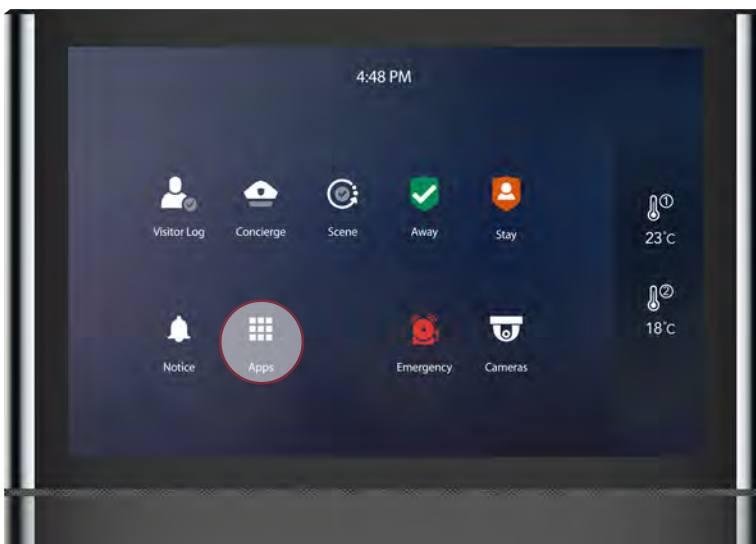

Once you are on the **Settings** page, click on **Language & input** and then click on **Language** at the top.  Please note – the remaining menu options are not functional for residents.



Language Settings

On the **Language** page, you can now change the language setting for your wall pad.



 Please note – at this time, only English and French are supported. If a resident selects another language, only a limited number of menu items will be translated. Therefore, they will need to change it back to either English or French.

8.6 Security -> Away-Stay Setting

This option allows you to adjust the settings related to the alarm in your suite. When selected, it will display the screen below.

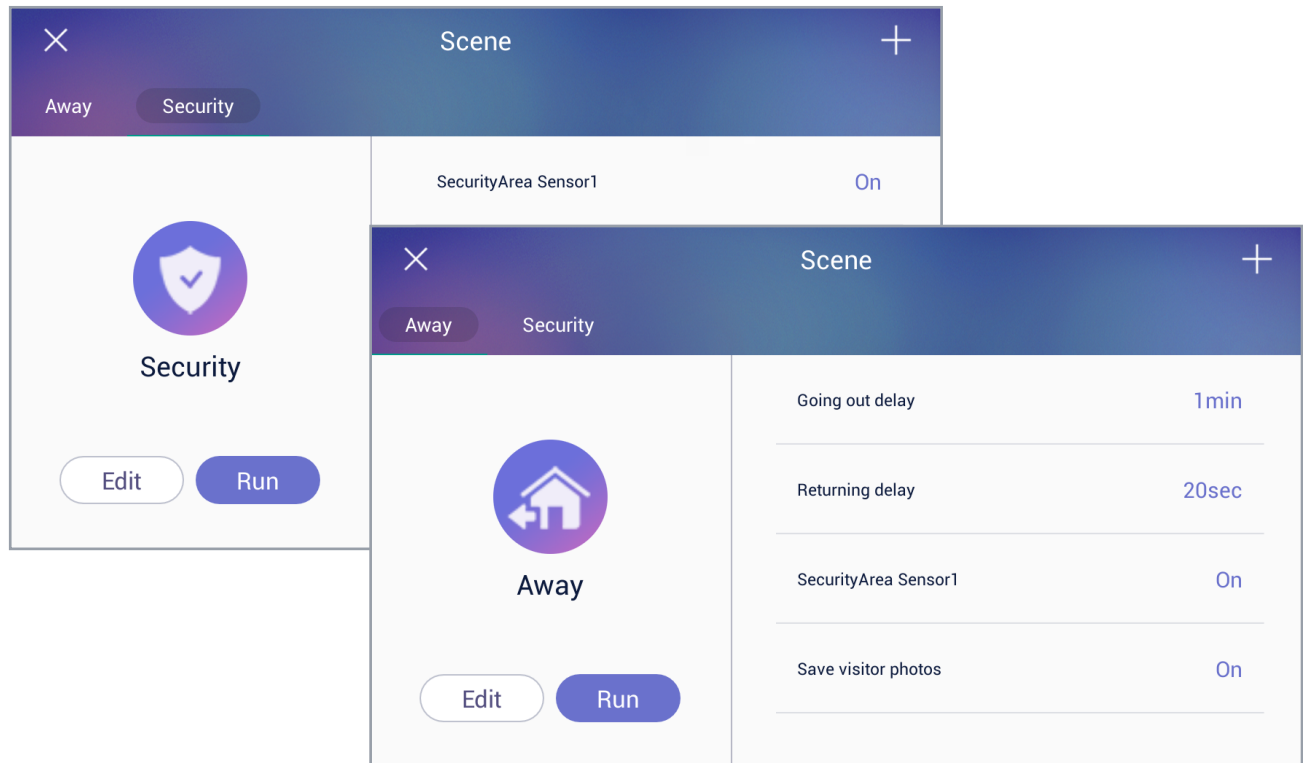

Screens to change the suite security system settings

The settings for 'Away' and 'Stay' may be selected using the buttons at the top of the screen. You may edit these settings or launch the security system using the 'Edit' and 'Launch' buttons on the left side of the screen.

Descriptions of the different settings:

- **Set Delay For Alarm** – This setting is the period of time from when you start the alarm until it becomes active. The purpose of this delay is to allow enough time for you to leave your home, before the alarm has been set.
- **Set Sensor Delay** – This setting is the period of time that you are given to deactivate your alarm before it starts to sound.
- **Area 01** – This area is the front door sensor. Turning it off will turn off the door sensor for the security system.
- **Area 03** – This selection is for additional motion detectors should your suite have them.
- **Capture Visitor Picture** – When this setting is ON, the picture of a lobby entrance visitor will automatically be captured when they call your suite and "Away Mode" is set. The purpose is to show you the picture of a person that visited while you were out.

8.7 Thermostat



⚙️ If your suite is integrated with HVAC thermostat controls the following describes how to control it.

The thermostat(s) for your suite can be accessed by pressing the 'Thermostat' icon on the right edge of the home screen. The temperature displayed on the icon is the current suite temperature. If your home has multiple thermostats, there will be more than one icon displayed and you can set each thermostat independently. The thermostat setting screen is shown below.

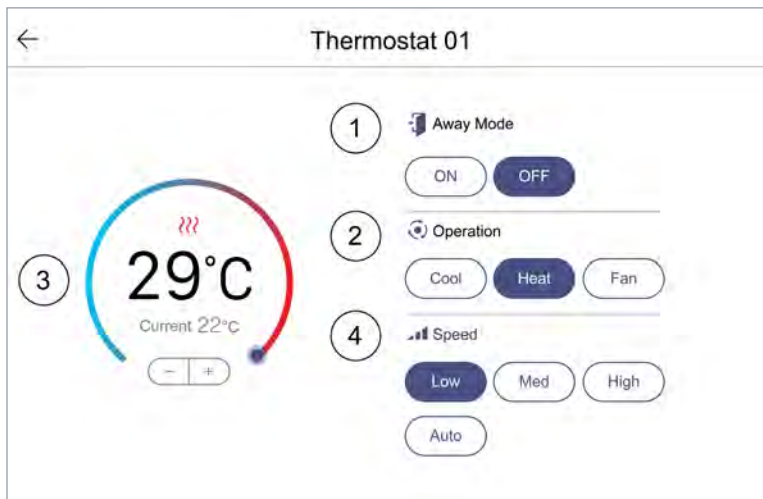

Thermostat Interface

⚙️ **Interface will be different based on your community HVAC**

Each thermostat can set a different temperature when in 'Away mode'. 'Away mode' is used to reset the temperature when your alarm has been activated and you're not home. This allows the option to reduce energy costs. We've numbered the features on the thermostat image above with explanations:

- ① The control button displayed is used to turn 'Away mode' On to allow you to set a desired temperature. When 'Away mode' is set to Off, normal operation continues.
- ② On the thermostat screen shown above is where the cooling, heating, or fan only function is set. Click on either Cool, Heat, or Fan as desired.
- ③ Shows where the temperature can be adjusted using the – and + symbols or by sliding the control ring.
- ④ On the thermostat screen shown above is where the fan speed is set. When Auto is selected, the fan coil will automatically set the optimal speed for the unit. Selecting Low, Med, or High will set the fan speed and override the Auto setting.

⚙️ **Due to the design of your HVAC system, some of these features may be unavailable based on your building requirements.**

Please note - some suites are designed with a two-pipe HVAC system and the heat function is only available in winter and cool function is only available in summer. Speak to your property manager for specific details.

8.8 Security password

The below Security Code Entry Screen is where you would reset your suite alarm password should you have forgotten your number. You can access this screen by selecting the 'Apps' menu from the home screen and then Settings -> User Configuration -> Password.

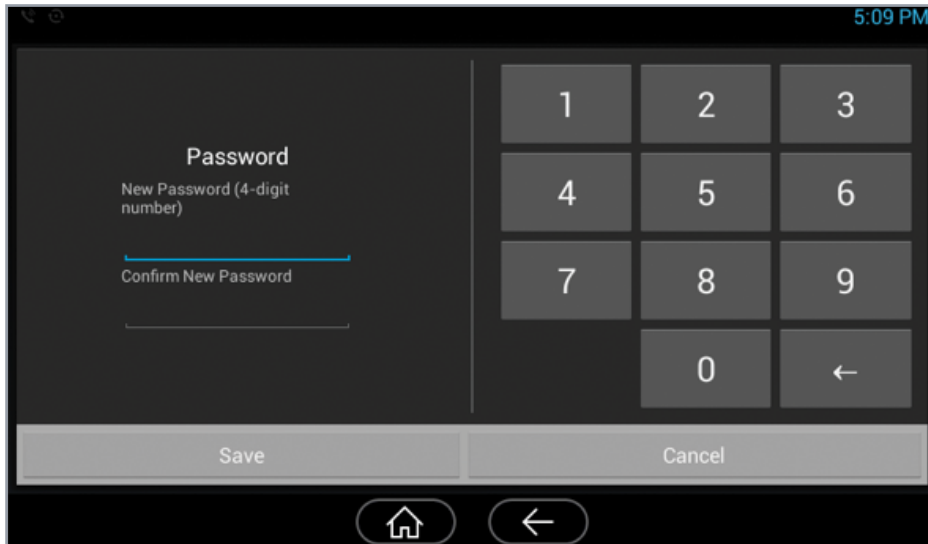

Security Code Entry Screen

Simply enter a four-digit password twice to confirm your new security code.

8.9 Settings -> Commax -> touch pad sensitivity

This option will allow you to adjust the touch pad sensitivity of the system. Selecting this option will display the screen below.

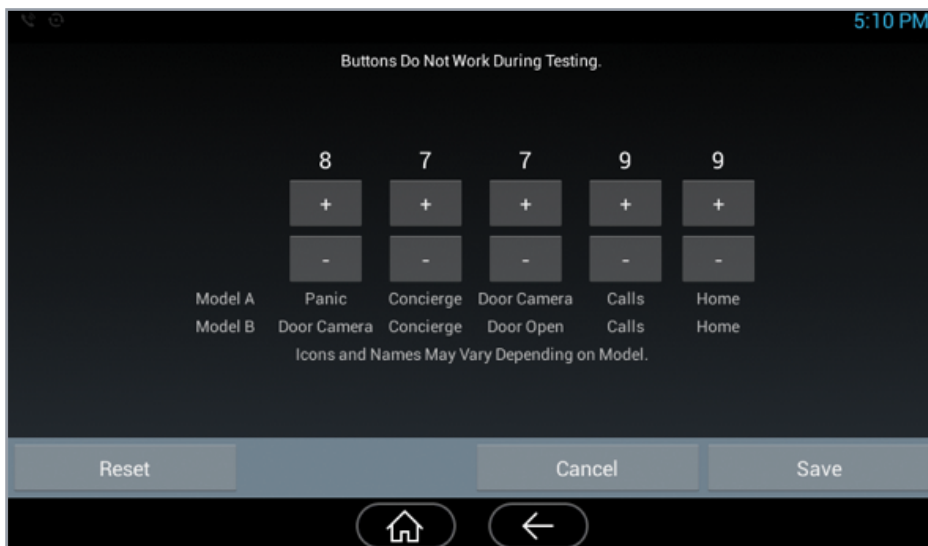

Touch Screen Sensitivity Adjustment

⚙️ Please note that touch screen sensitivity is increased when the numbers are lower.

Amenity Booking

The following section demonstrates how you can book any amenities that may be available in your community. Below are some examples.

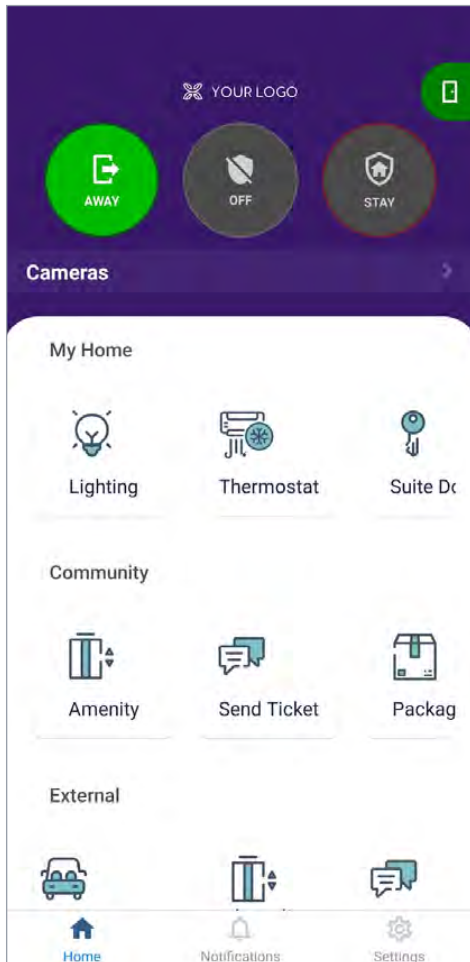

ONE! App Home Screen

From the main page, click on **Amenity** and it will take you to the next screen where you can see all your booked amenities.

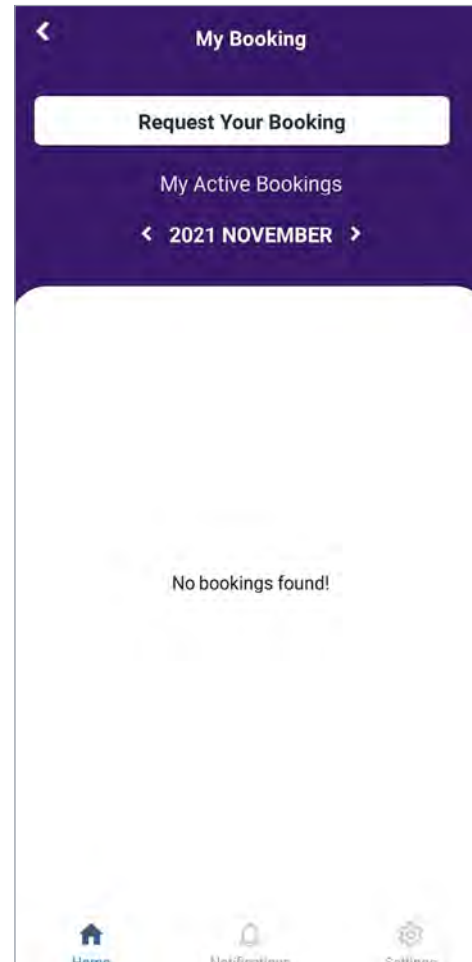

My Booking Screen

This screen also allows you to request a booking for a new amenity. A new amenity can be booked by clicking on **Request Your Booking**, which will take you to the screen on the following page.

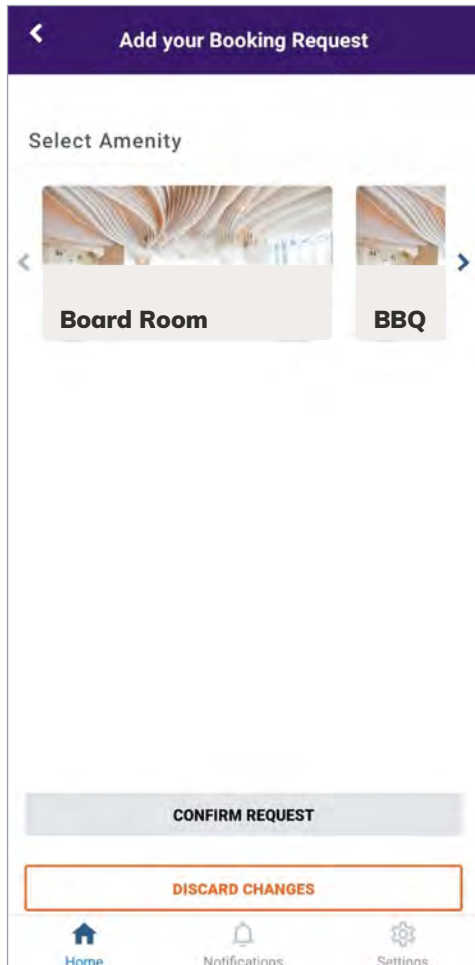

Select Amenity

Here, you will see the list of all the amenities available in your community and can select the amenity.

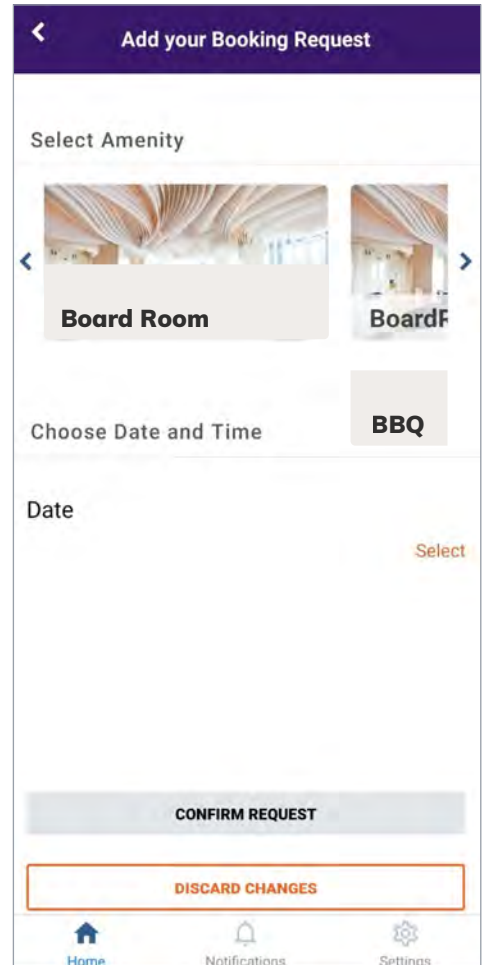

Fill Details

Once you have selected an amenity, fill in the details – **Date** and **Time**.

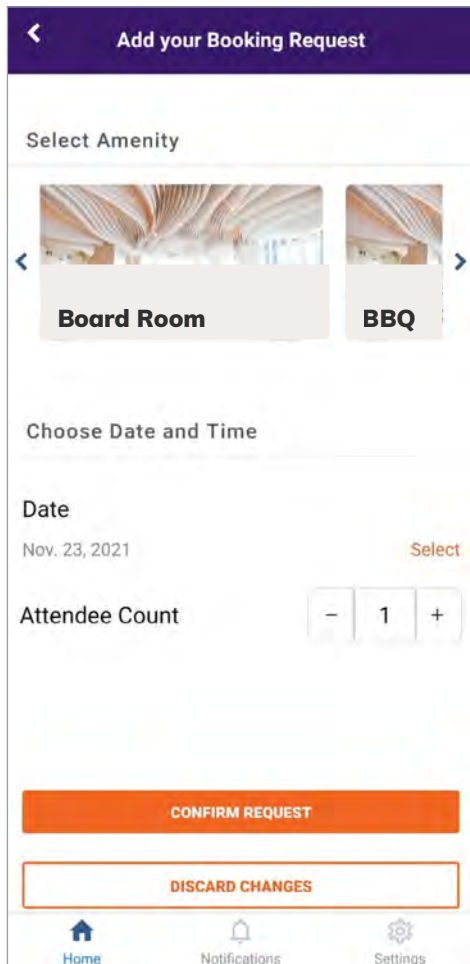

Confirm Request

After selecting a date and time for your amenity booking, the screen will show you the booking details that have been entered. Click **Confirm Request** to proceed or if you would like to change the details, click **Discard Changes** to reselect your **Date** and **Time**.

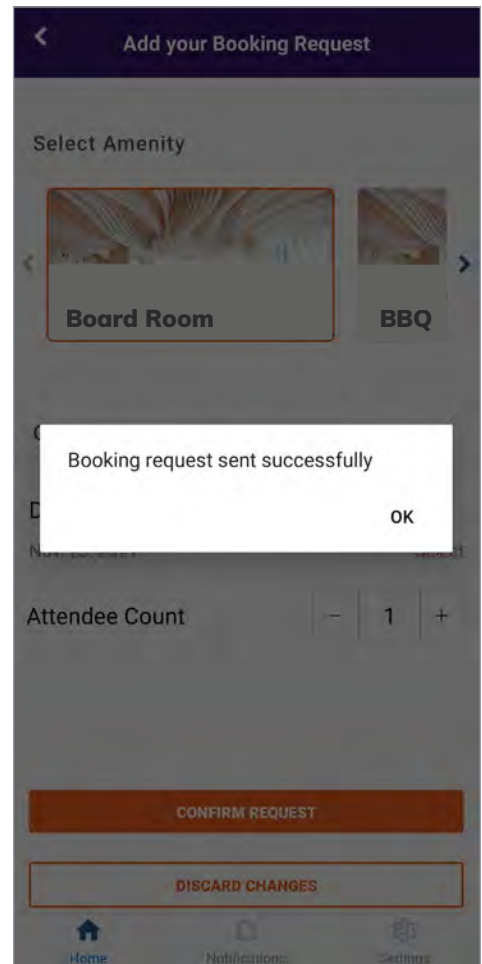

Await Approval

Once you confirm your request, the screen will show the booking request has been sent to the property manager for their approval.

Outside Body Name & Function

	NAME	FUNCTION
①	Keypad	Enter the number when registering or changing password
②	Battery warning light	Turns on with an audible alarm when battery charge is low
③	Smart fob input unit	It is the place where smart fobs are recognized to open the door
④	Outdoor Handle	It is used to open or close doors from outside the suite
⑤	Emergency power terminal	In case the battery is completely discharged, a 9V battery can be placed here to provide enough power to access the suite

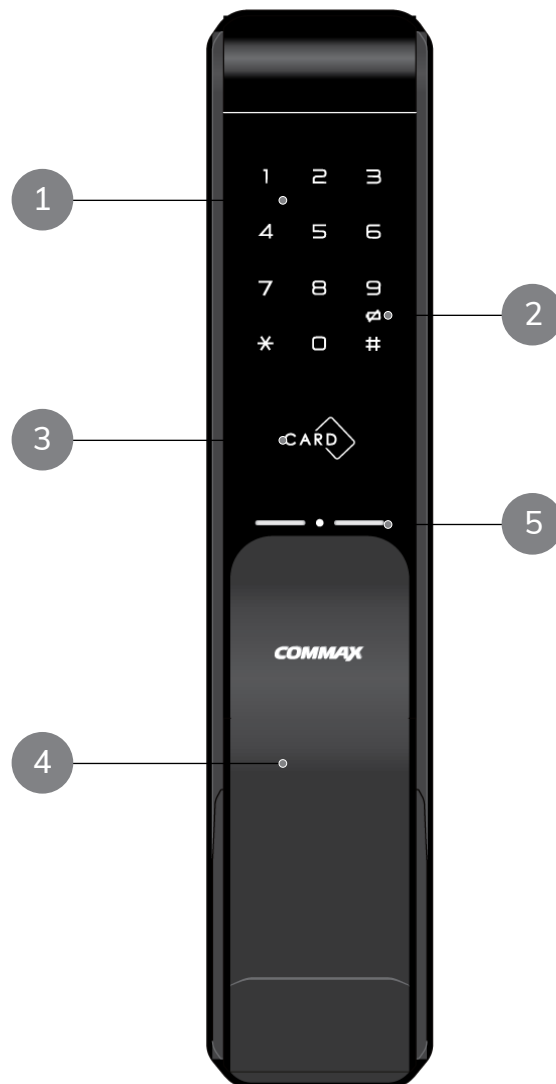

Model:

CDL-200P

Inside Body Name & Function

	NAME	FUNCTION
①	Battery cover	This cover protects the batteries and the registration button
②	Interlocking pack	Receive (CDL-447, optional)
③	Registration button	It is used to register or change password or smart fobs
④	Mortise	It is attached to the side of the door and closes or locks the door
⑤	Dead bolt	It locks the door by locking it on the door frame
⑥	Latch bolt	It serves to keep the door from shaking
⑦	Alkaline AA Battery	It is the power source to operate the door lock
⑧	Double lock button	Used to lock the door so that it cannot be opened from outside
⑨	Indoor Handle	It is used to open or close the door from inside the suite

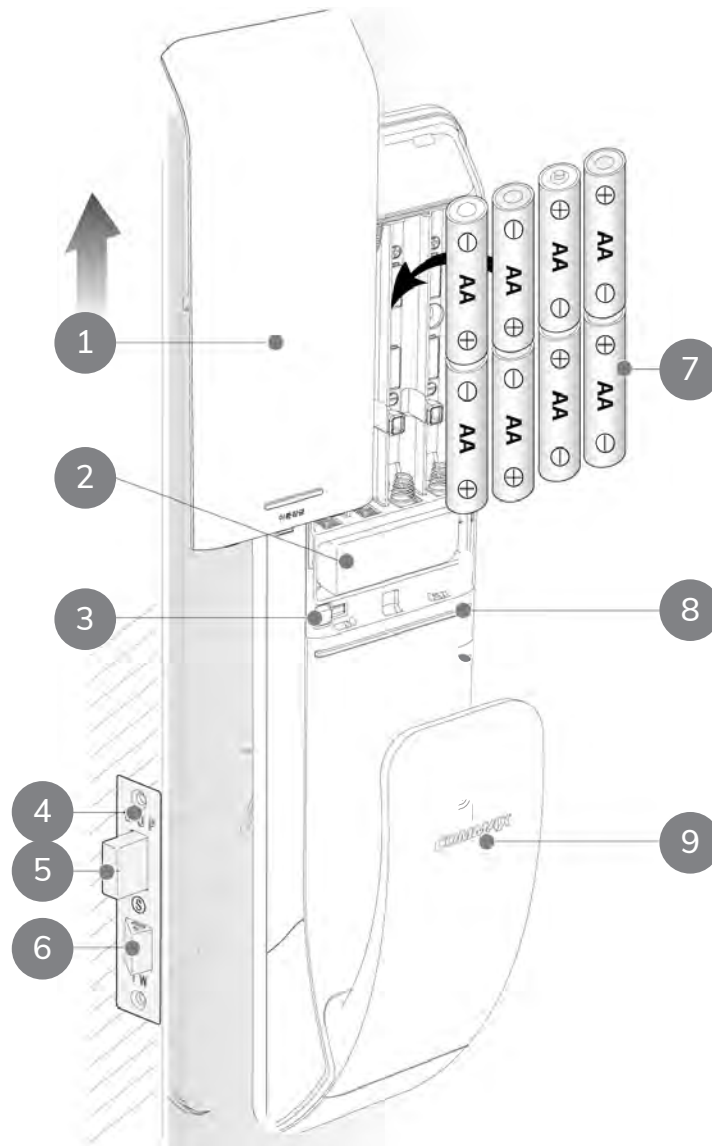

Outside Body Name & Function

	NAME	FUNCTION
①	Keypad	Enter the number when registering or changing password
②	Battery warning light	Turns on with an audible alarm when battery charge is low
③	Smart fob input unit	It is the place where smart fobs are recognized to open the door
④	Outdoor Handle	It is used to open or close doors from outside the suite
⑤	Emergency power terminal	In case the battery is completely discharged, a 9V battery can be placed here to provide enough power to access the suite

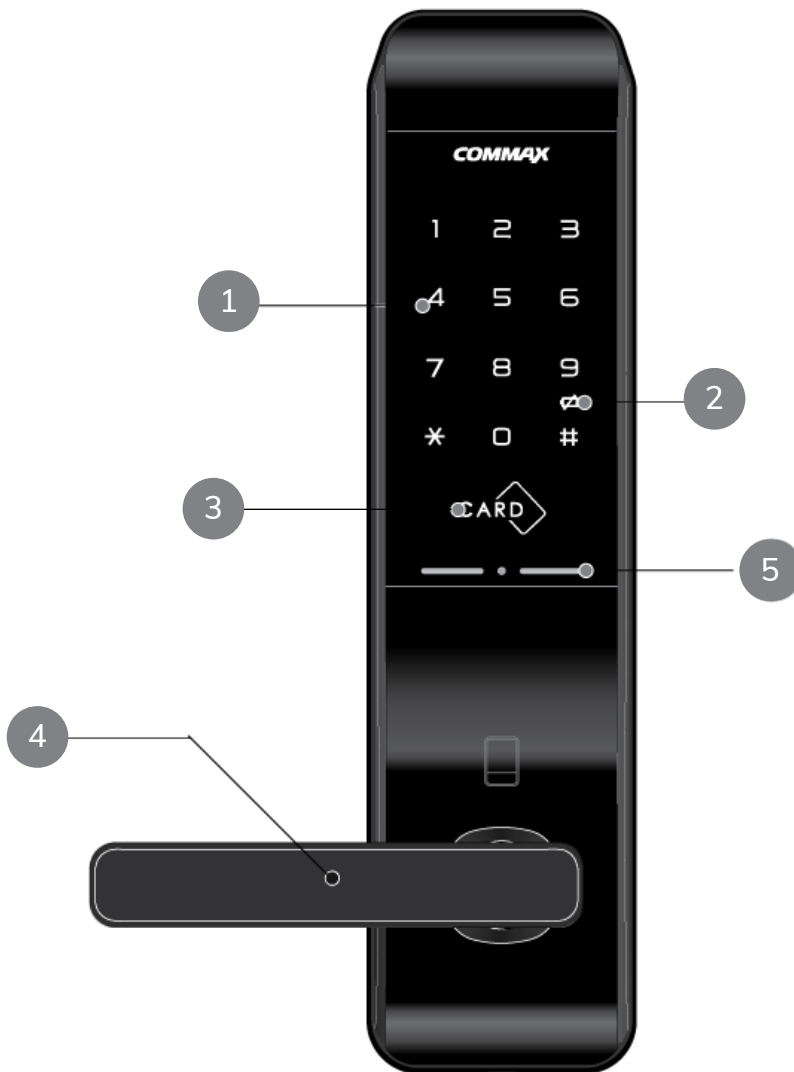

Model:

CDL-200L

Inside Body Name & Function

	NAME	FUNCTION
①	Battery cover	This cover protects the batteries and the registration button
②	Interlocking pack	Receive (CDL-447, optional)
③	Registration button	It is used to register or change password or smart fobs
④	Mortise	It is attached to the side of the door and closes or locks the door
⑤	Dead bolt	It locks the door by locking it on the door frame
⑥	Latch bolt	It serves to keep the door from shaking
⑦	Alkaline AA Battery	It is the power source to operate the door lock
⑧	Double lock button	Used to lock the door so that it cannot be opened from outside
⑨	Indoor Handle	It is used to open or close the door from inside the suite

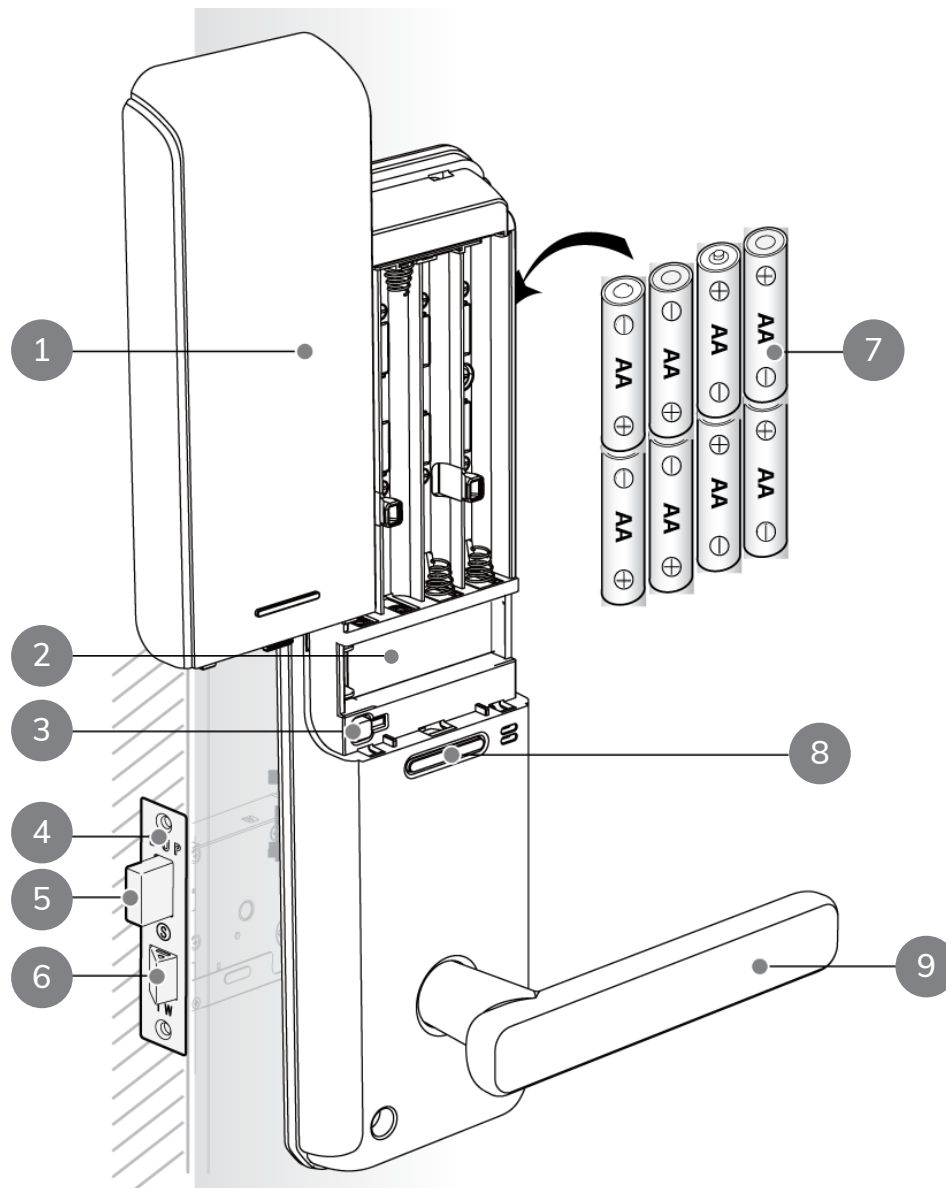

Locking/Double Locking your door from the inside

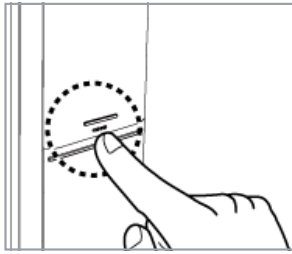

Inside

Locking your suite from the inside

Push the inside [double lock] button and the door will lock.

⚙️ Please note: access to your suite will still be granted to users with the correct PIN code or smart fob.

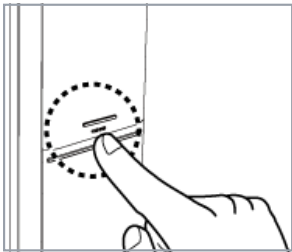

Inside

Double Locking your suite from the inside

Push the inside [double lock] button for 3 seconds to lock the door from all outside access (including those with PIN code or smart fob).

⚙️ Please note: you will be able to exit your suite at anytime. However, access to your suite will be denied to all users even those using the correct PIN code or smart fob.

⚙️ Please note: in case of an emergency, the master smart fob will be able open the door whether the door is locked or double locked.

Locking your door from the outside

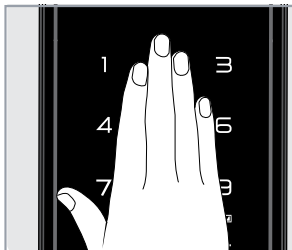

Outside

Locking your suite from outside

Touch the keypad when you leave your suite to lock the door.

Setting up Access - PIN Numbers

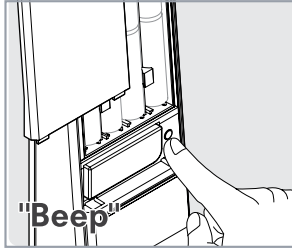

Inside

Step 1.

Open the door and remove the battery cover to access the Registration button. Push the button until you hear a Beep sound.

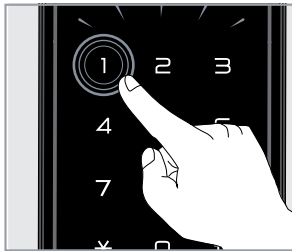

Outside

Step 2.

The [Keypad] will illuminate.
Push the button Number 1.

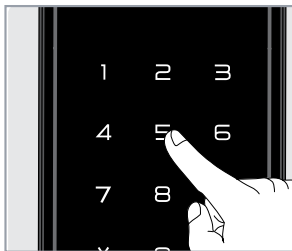

Outside

Step 3.

Enter a 4 to 12 digit private PIN code.

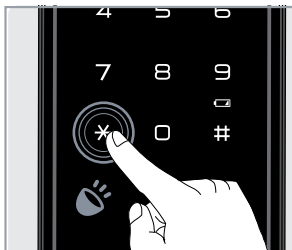

Outside

Step 4.

Push the [*] button. A "Beep" sound will confirm the registration.
You can now enter additional PIN codes at this time and push [*] after each. Press the [*] button once more to complete the registration process of all PINs.

 Do not use consecutive numbers when registering your PIN code.

 For your security, adding additional PIN code will automatically delete all existing PIN codes. If you require multiple PIN codes they must be registered during the same session.

- To add additional PIN codes, repeat step 3 and 4 above, before the keypad lights turns off.
- You can register up to a maximum of four (4) PIN codes.

Setting up Smart Fobs

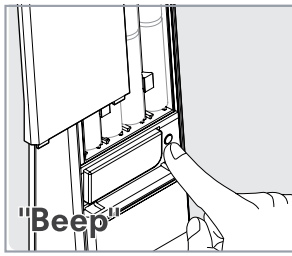

Inside

Step 1.

Open the door and remove the battery cover to access the Registration button. Push the button until you hear a Beep sound.

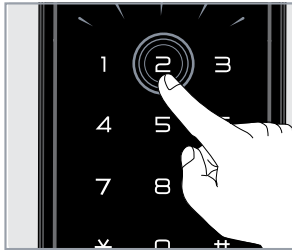

Outside

Step 2.

The [Keypad] will illuminate.
Push the button Number 2.



Outside

Step 3.

Hold smart fobs close to the reader. There will be a "Beep" sound when the registration is successful. You can register multiple smart fobs at this time. The registrations must occur before the keypad goes dim.



Inside

Step 4.

Push the [Register] button when you have finished registering all of your smart fobs.

 Smart fobs are available from your Property Management team for an additional cost.

 Registering a new smart fob will wipe out all existing ones. If you require multiple smart fobs they must be registered during the same session.

- To add new smart fobs, repeat steps 3 to 4 above, before the keypad lights turn off.
- You can add up to thirty (30) smart fobs on your smart lock.

Delete All Smart Fobs

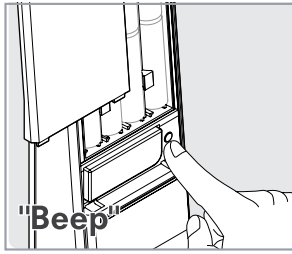

Inside

Step 1.

Open the door and remove the battery cover to access the Registration button. Push the button until you hear a Beep sound.



Outside

Step 2.

The [Keypad] will illuminate.
Push button Number 7 to delete all smart fobs.



Outside

Step 3.

Press and hold [#] button for 5 seconds to delete all registered smart fobs.

Unlocking your suite door with Keypad

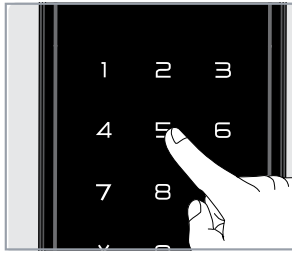

Outside

Step 1.

Touch smart lock to light up keypad.

Enter your code.



Outside

Step 2.

Push the [#] button and there will be a beep sound and the door will unlock.

⚙️ As a safety precaution, you can input up to 20 numbers and as long as your PIN exists in the sequence of numbers the smart lock will still open when you press [*].

Unlocking your suite door with the ONE! app

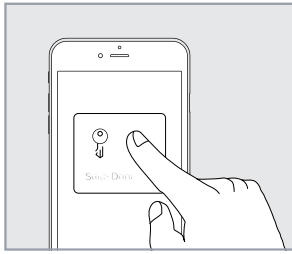

Outside

Step 1.

On the homepage of the ONE! app click on 'Suite Door'. Once the screen loads press the 'Unlock' button.



Outside

Step 2.

There will be a beep sound and the door will unlock.

Unlocking your suite door with Smart Fob

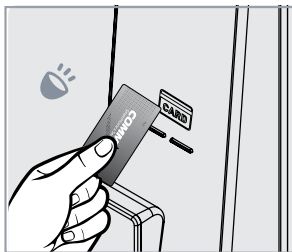

Outside

Step 1.

Registered [smart fob] close to [smart fob] access point.



Step 2.

There will be a beep sound and the door will unlock.

Tamper Alarm

If there are 5 failed attempts to enter a PIN code or 5 failed attempts with a smart fob, the smart lock will seize operation and sound alarm for 1 minute.

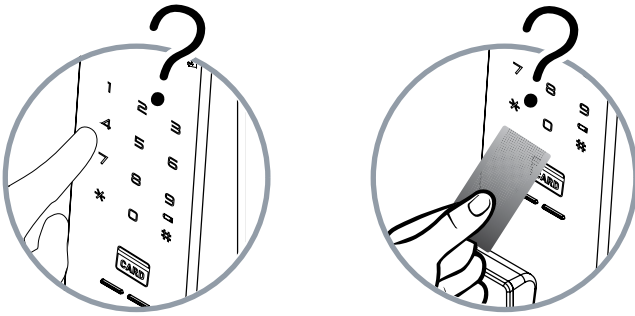

Battery Replacement Warning

When the batteries run low, the battery icon light will illuminate and the smart lock will make a beeping sound.

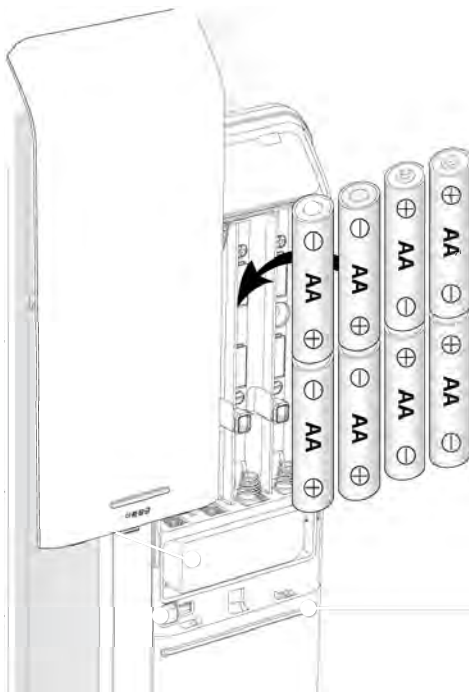

- ⚠ Do not mix used batteries and new batteries. Please replace all batteries with new ones. Use only AA alkaline batteries.

Error Codes

The digital door lock will flash numerical error codes on the keypad. The different error codes and their meanings are presented in the chart below.

FLASHING NO.	DESCRIPTION
1	If there were 5 or more incorrect pin codes or FOB attempts, the smart lock alarm will sound and be disabled for one minute.
2	PIN number/smart fob registration failed.
3	Maximum quantity of PIN codes have been stored.
4	Deadbolt is jammed or blocked by foreign object.
5	Tamper alert, someone is trying to force the lock.
6	Unregistered PIN code was used.
7	Unregistered FOB was used.
8	Fire Alert. The smart lock is sensing a high temperature in the suite.
9	Dual lock activated from inside.

Battery Failure - Backup Power

If the batteries in the smart lock are completely discharged, then use a 9V battery as shown in the diagram below to power the smart lock.

Step. 1

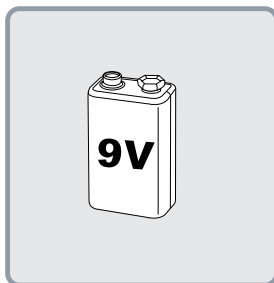

Get a 9V battery.

Step. 2

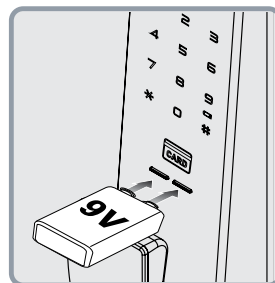

Hold it on terminals.

Step. 3

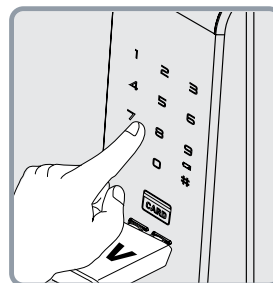

Press the [*] button then input [Passcode].

Step. 4

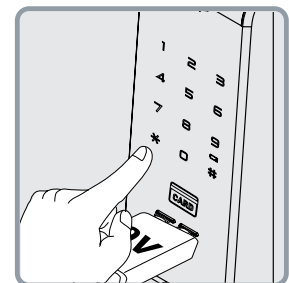

Push the [*] button and it will beep and the door will open.

 The polarity of the battery doesn't matter, the battery can be placed either way on the contacts.

Adjust Digital Door Lock Sound Volume

See the steps below to raise or lower the volume of the sounds you hear when pressing the codes on your digital door lock.

 Please note - the door must be in the locked position, so you need to be outside your suite to adjust the volume setting.

Step. 1

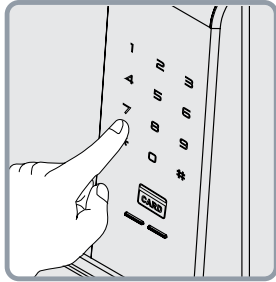

Enter your pin code

Step. 2

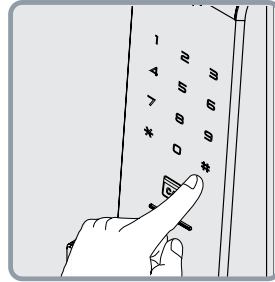

Press the # button

Step. 3

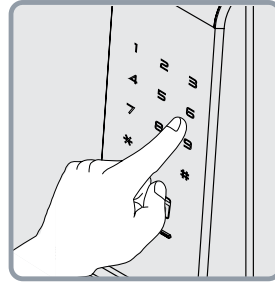

Press 6 to lower the volume of the beeps or press 3 to raise the volume

Step. 4



Press * when completed

Additional support

If there is an **immediate issue** where your suite wall pad or smart lock is not functioning, **please contact your community's Customer Care and an urgent support ticket will be launched immediately.**

For any additional assistance, please call your property manager.

